



FBT

J

Speaker Systems

 **МУЗЦЕНТР**
МУЗЫКАЛЬНОЕ ОБОРУДОВАНИЕ
<https://muzcentre.ru>

*Designed, Engineered
and Manufactured in ITALY*

ENGLISH

FBT elettronica SpA

Via Paolo Soprani 1 - Zona Ind.le Squartabue - 62019 RECANATI - ITALY Tel. 071 750591 - Fax. 071 7505920 - email: info@fbt.it - www.fbt.it

INDEX

WARNING - IMPORTANT SAFETY INSTRUCTIONS - PRECAUTIONS	1
GENERAL FEATURES	2-3-4-5-6
POWER SUPPLY	7
CONNECTORS	8
ACCESORIES	9-10-11-12
SAFETY INSTRUCTIONS	13
INSTALLATION MODE	14-15
CONTROLS AND FUNCTIONS	16-17-18-19-20-21
CONNECTION EXAMPLES	22-23-24-25-26
TECHNICAL SPECIFICATIONS	27



WARNING

RISK OF ELECTRIC SHOCK
DO NOT OPEN



**TO REDUCE THE RISK OF ELECTRIC SHOCK
DO NOT REMOVE COVER (OR BACK)
NO USER SERVICEABLE PARTS INSIDE
REFER SERVICING TO QUALIFIED SERVICE PERSONNEL**

**TO REDUCE THE RISK OF FIRE OR ELECTRIC SHOCK
DO NOT EXPOSE THIS EQUIPMENT TO RAIN OR MOISTURE**



WHERE MARKED, THIS SYMBOL INDICATES A DANGEROUS NON-ISOLATED VOLTAGE INSIDE THE LOUDSPEAKER. SUCH VOLTAGE COULD BE SUFFICIENT TO RESULT IN THE RISK OF ELECTRIC SHOCK.



WHERE MARKED, THIS SYMBOL INDICATES IMPORTANT USAGE AND MAINTENANCE INSTRUCTIONS IN THE ENCLOSED DOCUMENTS. PLEASE REFER TO THE MANUAL.

IMPORTANT SAFETY INSTRUCTIONS

- 1) Read these instructions
- 2) Keep these instructions
- 3) Heed all warnings
- 4) Follow all instructions
- 5) Do not use this apparatus near water
- 6) Clean only with dry cloth
- 7) Do not block any ventilation openings. Install in accordance with the manufacturer's instructions.
- 8) Do not install near any heat sources, such as radiators, heat registers, stoves or other apparatus (including amplifiers) that produce heat
- 9) Do not defeat the safety purpose of the polarized or grounding-type plug. A polarized plug has two blades with one wider than the other. A grounding type plug has two blades and a third grounding prong. The wide blade or the third prong are provided for your safety. If the provided plug does not fit into your outlet, consult an electrician for replacement of the obsolete outlet.
- 10) Protect the power cord from being walked on or pinched particularly at plugs, convenience receptacles, and the point where they exit from the apparatus.
- 11) Only use attachments/accessories specified by the manufacturer.
- 12) Use only with the cart, stand, tripod, bracket, or table specified by the manufacturer or sold with the apparatus. When a cart is used, use caution when moving the cart/apparatus combination to avoid injury from tip-over.
- 13) Unplug this apparatus during lightning storms or when unused for long periods of time.
- 14) Refer all servicing to qualified service personnel. Servicing is required when the apparatus has been damaged in any way, such as power-supply cord or plug is damaged, liquid has been spilled or objects have fallen into the apparatus, the apparatus has been exposed to rain or moisture, does not operate normally, or has been dropped.



THE DEVICE MUST BE CONNECTED TO THE MAINS THROUGH A POWER OUTLET WITH A PROTECTIVE EARTH CONNECTION.

This device features a power outlet ; install the device so that the outlet for the power cord is easily accessible .

PRECAUTIONS

- * For proper air ventilation please make sure to leave sufficient clearance (min 11 inc.) on all sides of the device.
- ° Please do not cover the ventilation slots with papers, table cloths, curtains, etc. in order not to prevent ventilation of the device.
- ° Please do not place any naked flame source, such as lighted candles, on the device.
- ° Please keep the device away from water springs and splashes and please do not place any objects containing liquids, such as vases, on the device.

GENERAL FEATURES

Our new «J» series is a highly technologically advanced range of products aimed to improve the performance of the previous line «JOLLY».

The «J» range is based on the development of three new highly efficient Class D amplifiers, completely designed at FBT's R&D laboratories and featuring the following wattage: 80W+40W for J15A model, 200W+50W for J8A model, 350W+100W for J12A and J15A models.

The new «J» series by FBT also includes a model specially designed for modern Djs: DJ15A . It is a polypropylene bi-amplified speaker with 15" woofer and DSP technology; its control panel features a two channel mixer.

«J» loudspeakers have been completely re-designed taking advantage of the developments of the last years, for achieving improved efficiency and linear response.

Thanks to its versatility, the «J» series is recommended for band PA, personal monitors, small theatres and auditoriums, piano bars, Djs, stage monitors and fixed installations in live clubs, pubs and gyms.



GENERAL FEATURES



- 5" custom woofer with improved efficiency and linearity
- 1" neodymium silk dome tweeter
- 80W RMS Class D amplifier for LF and 40W RMS for HF
- On-board analog signal processing with limiter
- Available in white colour



- 5" custom woofer with improved efficiency and linearity
- 1" neodymium silk dome tweeter
- Input panel with jack and terminal connector for bare wires
- Available in white colour



- 5" custom woofer with improved efficiency and linearity
- 1" neodymium silk dome tweeter
- 4 position volume selector (3W-12,5W-25W-50W)
- Input panel with terminal connector for bare wires
- Available in white colour

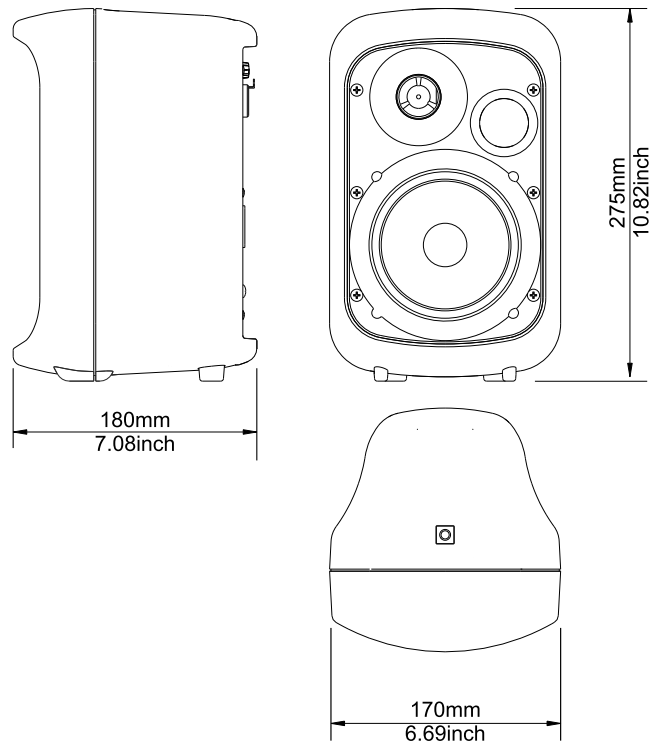

GENERAL FEATURES



- 8" custom woofer with improved efficiency and linearity
- 200W RMS Class D amplifier for LF and 50W RMS for HF
- Digital signal processor with equalisation and dynamic protection, 2 equalisation presets for «general purpose» or bass boosting applications.
- Available in white colour



- 8" custom woofer with improved efficiency and linearity
- NL4 Neutrik Speakon input & link connectors
- Available in white colour

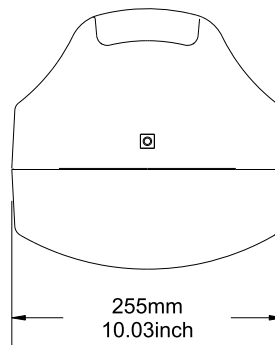
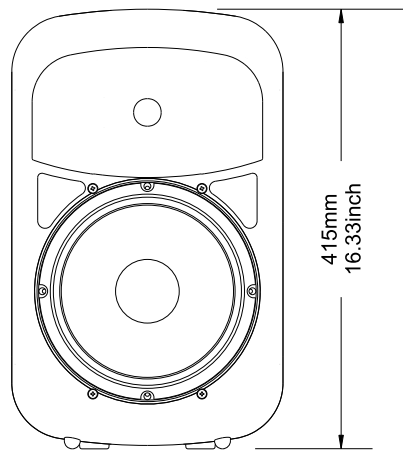
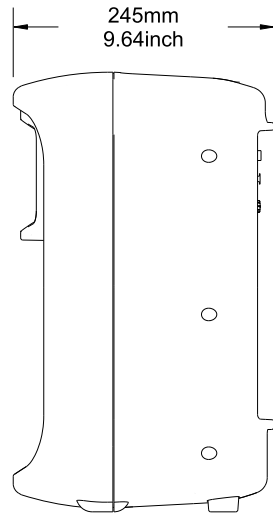

GENERAL FEATURES



- 12" custom woofer with improved efficiency and linearity
- 350W RMS Class D amplifier for LF and 100W RMS for HF
- High efficiency switch mode power supply
- Digital signal processor with equalisation and dynamic protection, 4 equalisation presets for «general purpose», voice or stage monitor applications, for musing listening at a moderate volume and for disco music



- 12" custom woofer with improved efficiency and linearity
- NL4 Neutrik Speakon input & link connectors

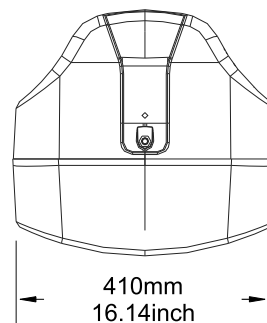
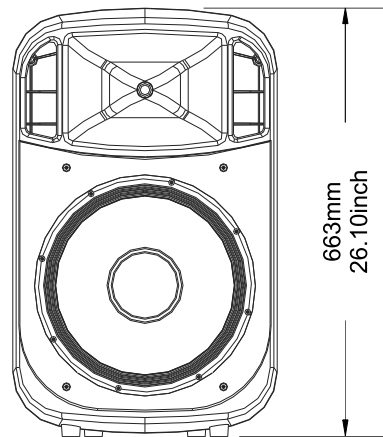
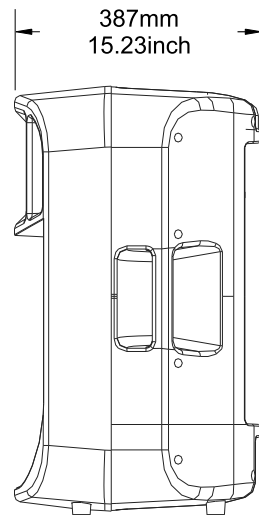

GENERAL FEATURES

15A

- 15" custom woofer with improved efficiency and linearity
- 350W RMS Class D amplifier for LF and 100W RMS for HF
- High efficiency switch mode power supply
- Digital signal processor with equalisation and dynamic protection, 4 equalisation presets for «general purpose», voice or stage monitor applications, for musing listening at a moderate volume and for disco music

15

- 15" custom woofer with improved efficiency and linearity
- NL4 Neutrik Speakon input & link connectors

DJ 15A

- 15" custom woofer with improved efficiency and linearity
- 350W RMS Class D amplifier for LF and 100W RMS for HF
- High efficiency switch mode power supply
- Digital signal processor with equalisation and dynamic protection
- 4 DSP preset specially designed for DJ users
- Two channel mixer input and stereo/mono output

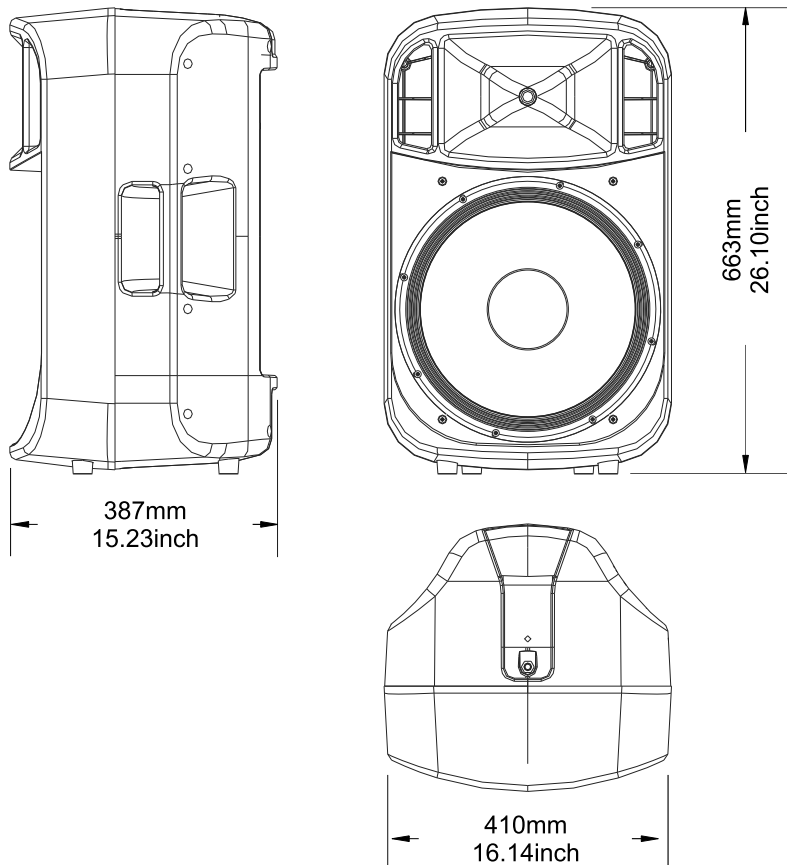

POWER SUPPLY

Before connecting the apparatus to the mains, make sure the supply voltage matches the one indicated on the back of the apparatus.

The power socket also included a fuse box; faulty fuses shall be replaced only with fuses having the same electrical features and value.

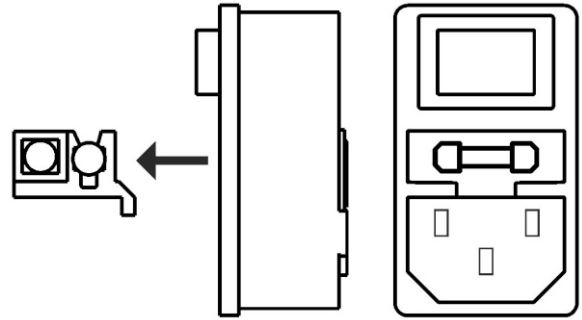

POWER SUPPLY 230V~

<p>J 5A</p> <p>220-230V~ 50/60Hz T630mAL - 250V 75VA</p>	<p>J 8A</p> <p>220-230V~ 50/60Hz T1.6AL - 250V 160VA</p>	<p>J 12A</p> <p>220-230V~ 50/60Hz T2.5AL - 250V 400VA</p>	<p>J 15A</p> <p>220-230V~ 50/60Hz T2.5AL - 250V 400VA</p>	<p>DJ 15A</p> <p>220-230V~ 50/60Hz T2.5AL - 250V 400VA</p>
---	---	--	--	---

POWER SUPPLY 120V~

<p>J 5A</p> <p>120V~ 60Hz T1.6AH - 250V 75VA</p>	<p>J 8A</p> <p>120V~ 60Hz T3.15AH - 250V 160VA</p>	<p>J 12A</p> <p>120V~ 60Hz T5AH - 250V 400VA</p>	<p>J 15A</p> <p>120V~ 60Hz T5AH - 250V 400VA</p>	<p>DJ 15A</p> <p>120V~ 60Hz T5AH - 250V 400VA</p>
---	---	---	---	--

CONNECTORS

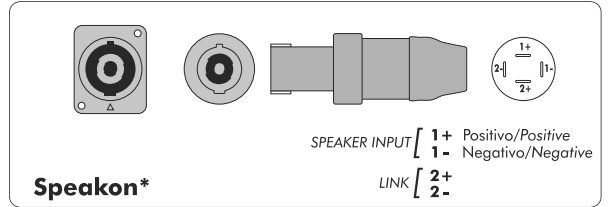
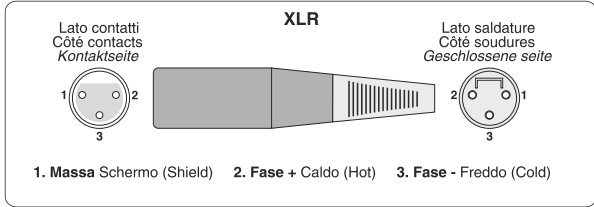
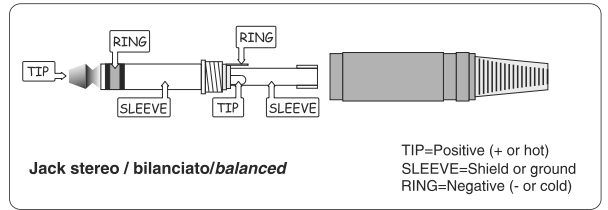
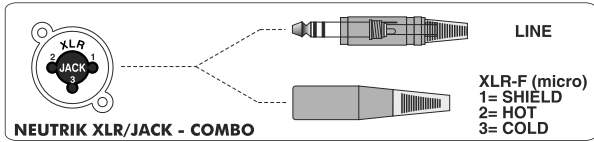

*SPEAKON is a registered trademark of NEUTRIK

CONNECTION CABLES

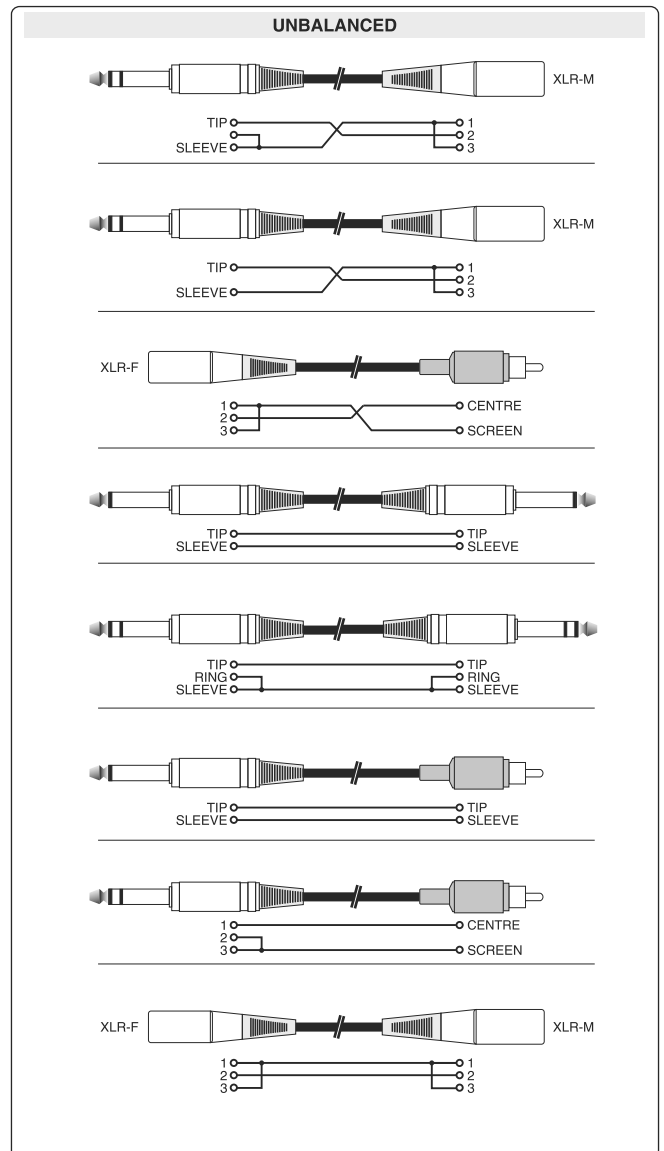
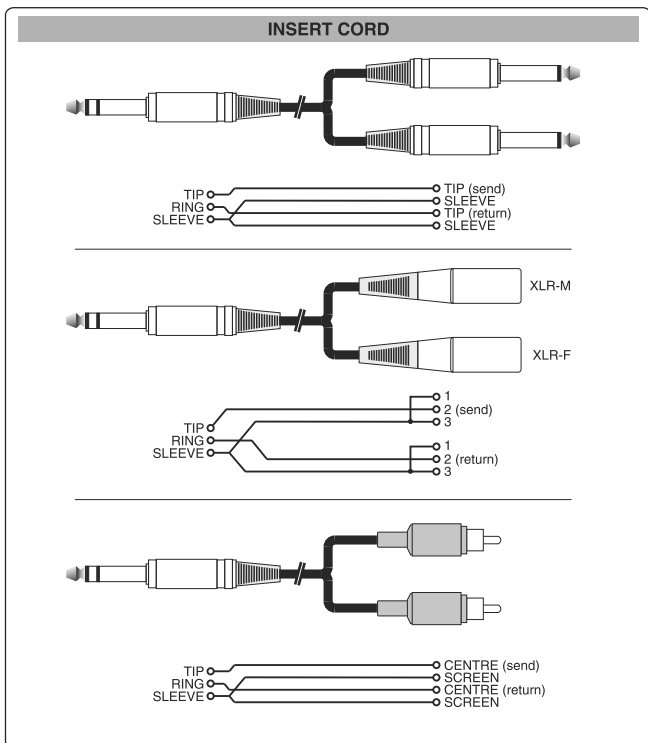
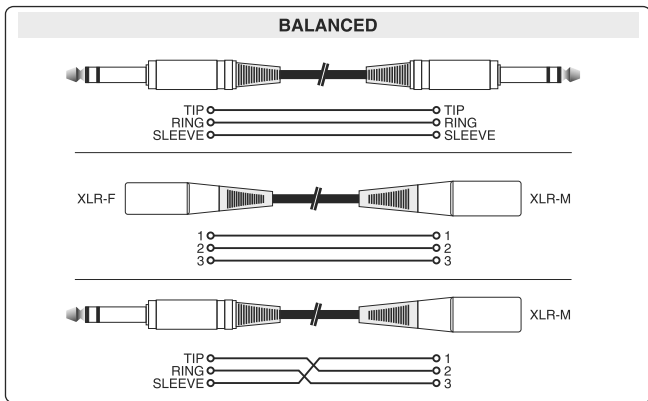

ACCESSORIES

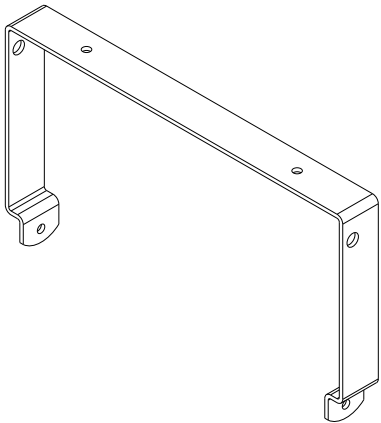

SJ 5U

Wall metal bracket to mount in horizontal position

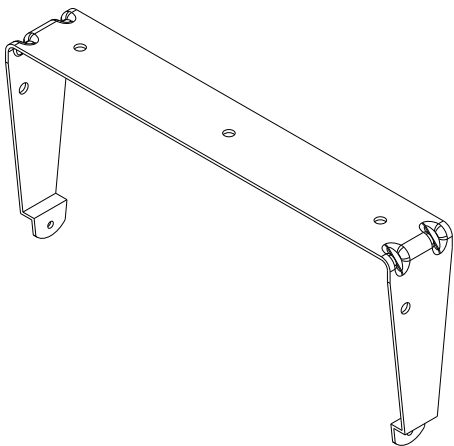
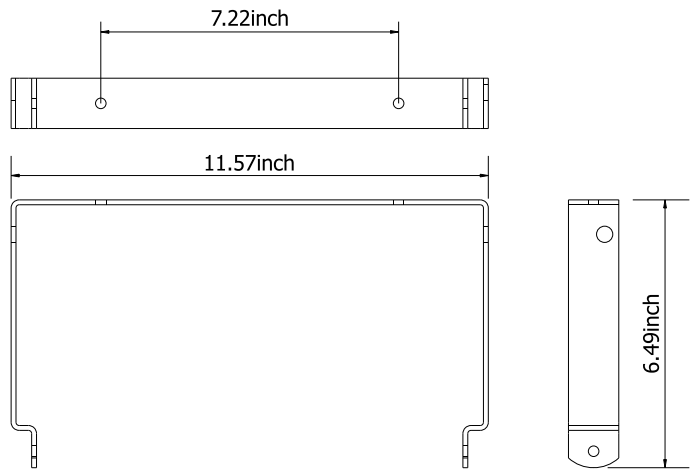

SJ 8U

Wall metal bracket to mount in horizontal position

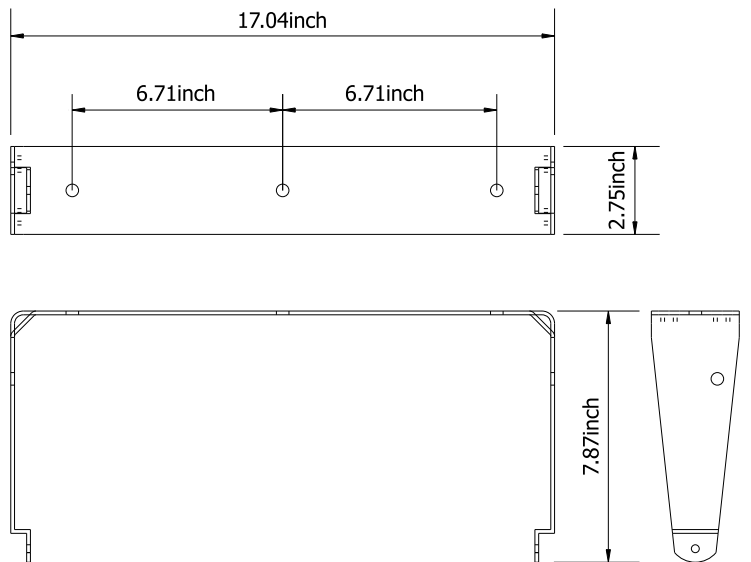

ACCESSORIES

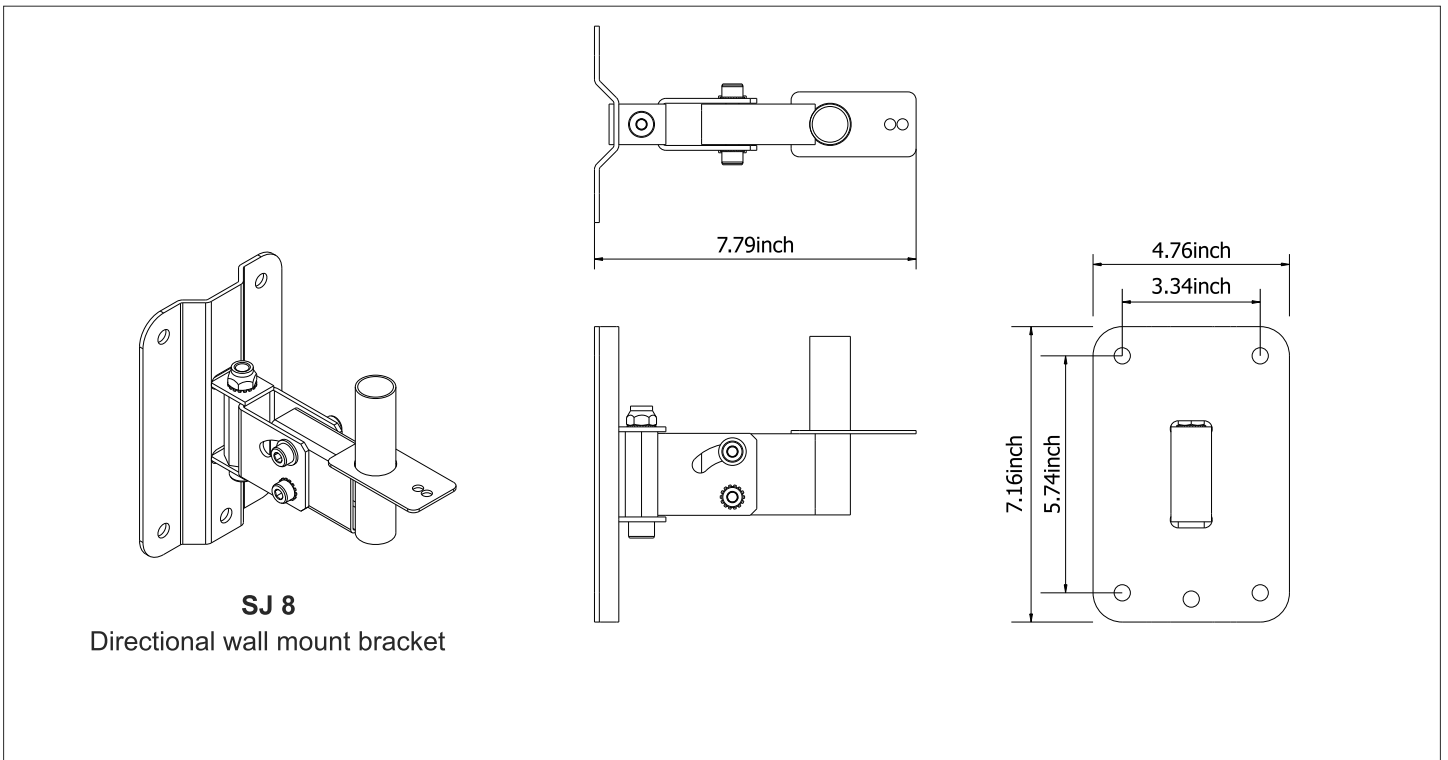
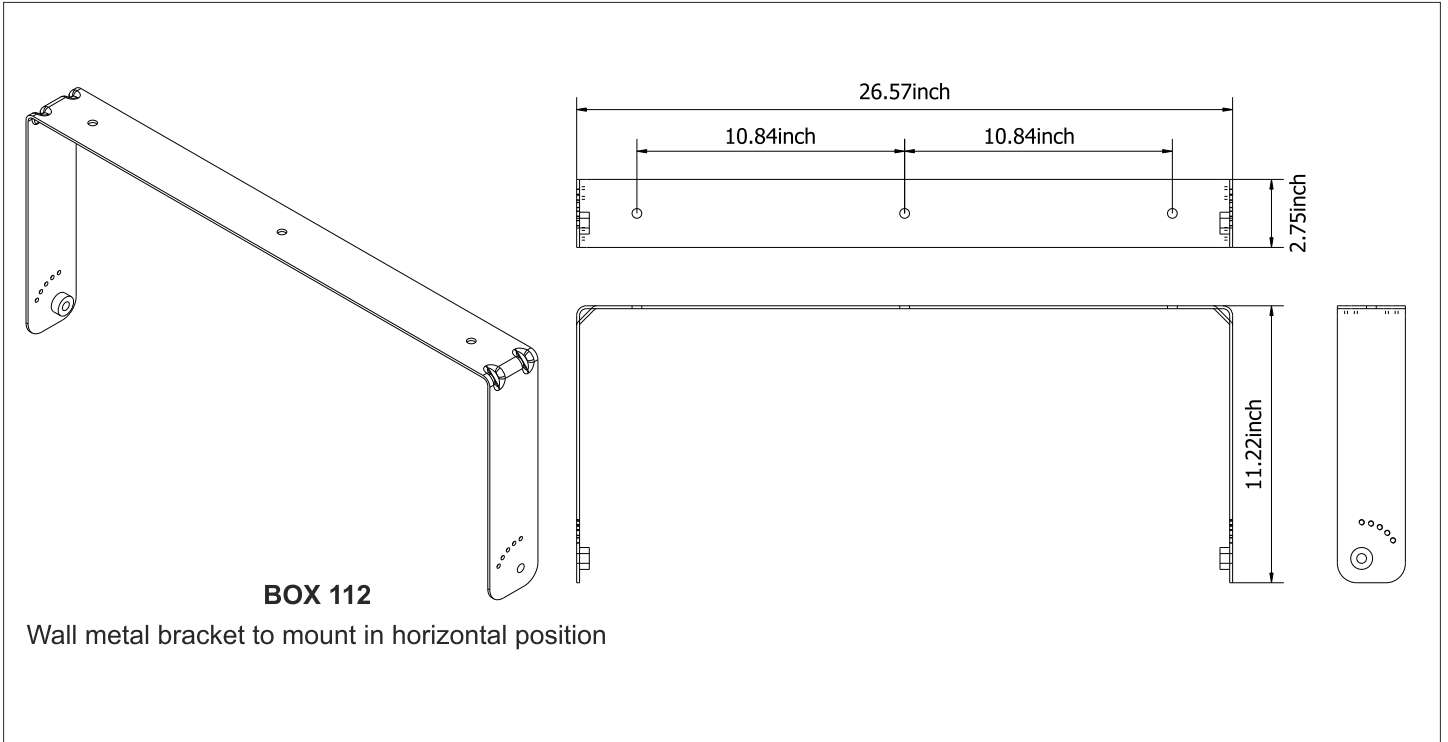

ACCESSORIES

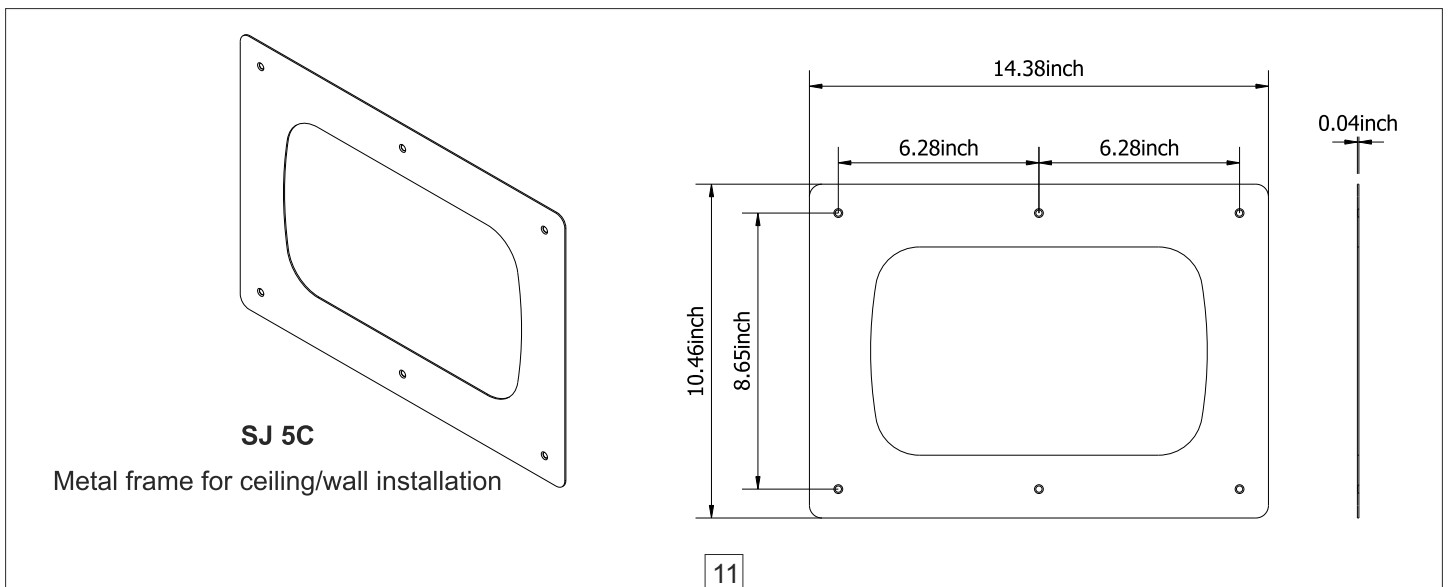
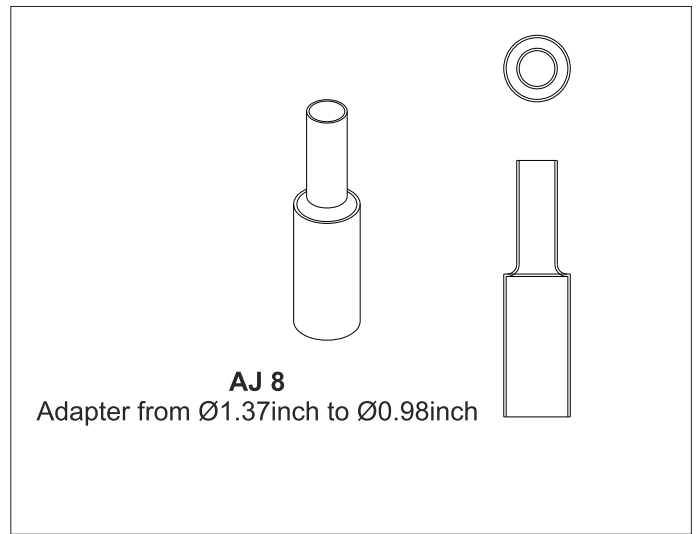
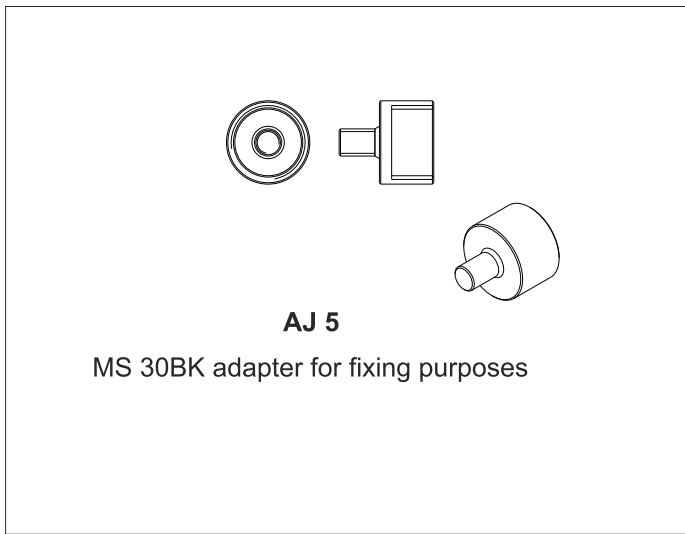
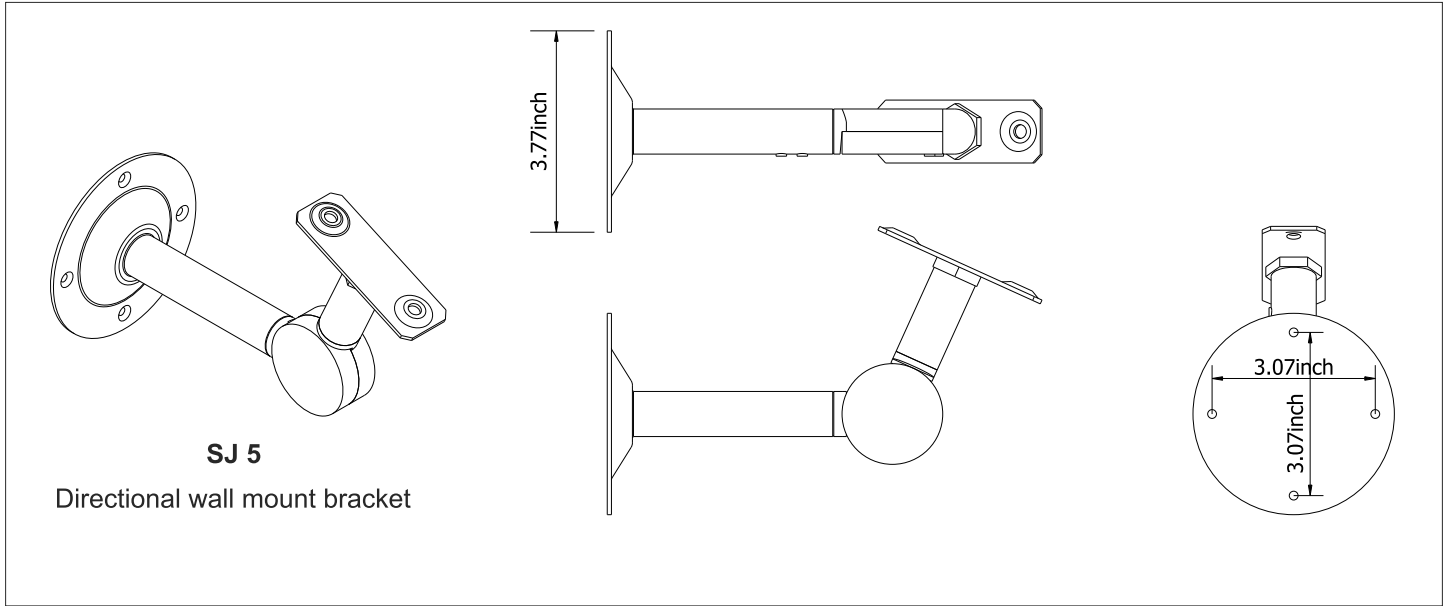

ACCESSORIES

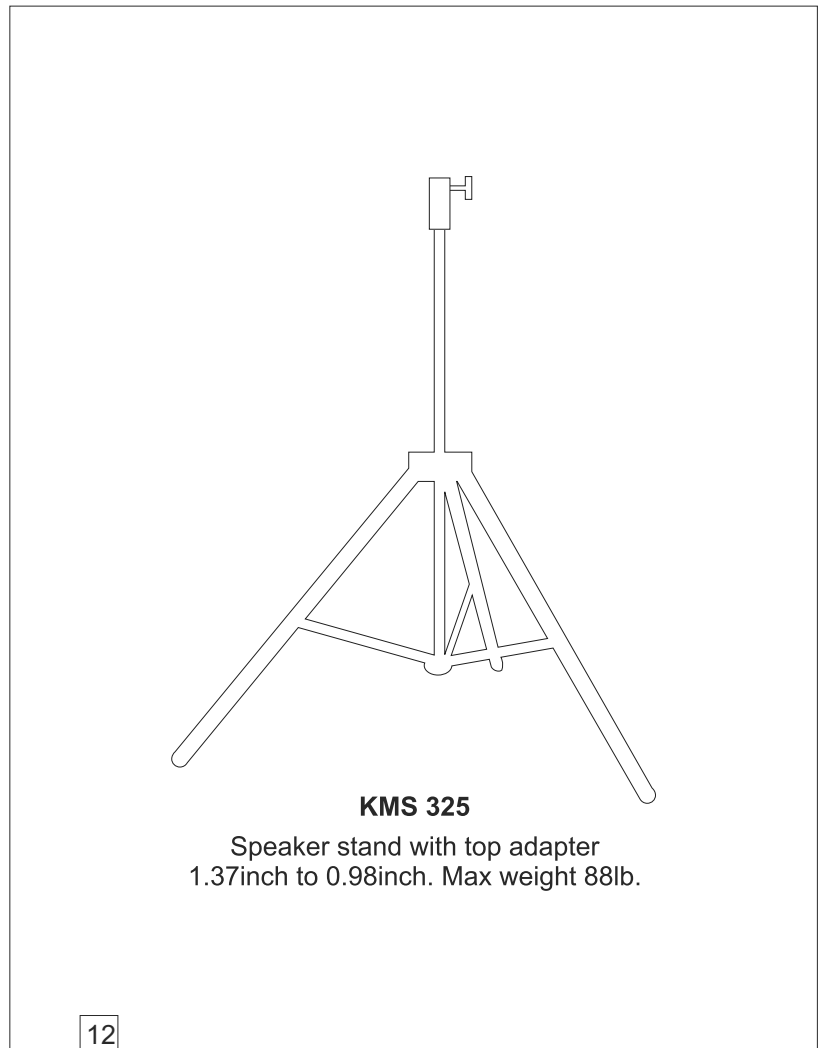
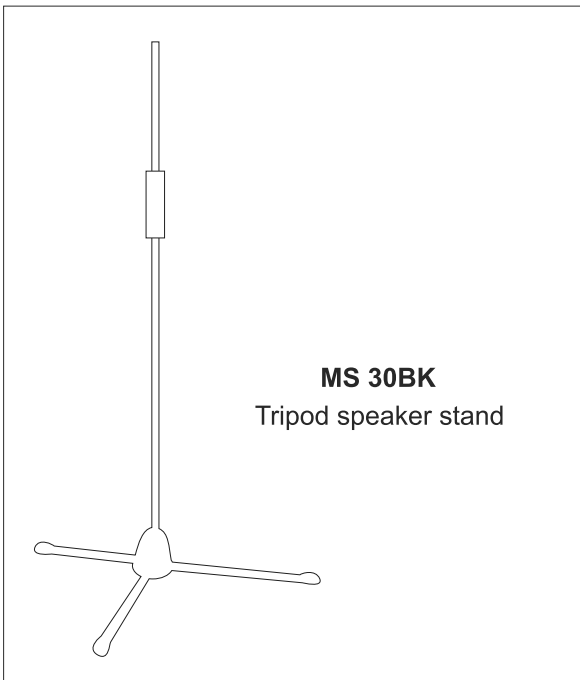
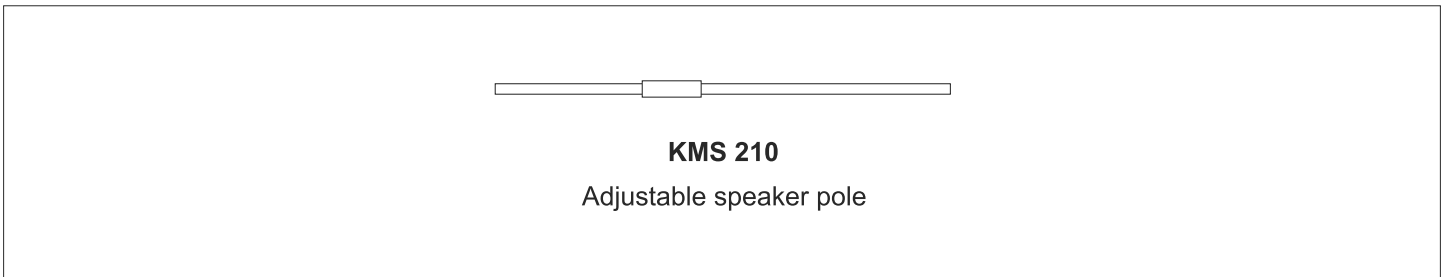
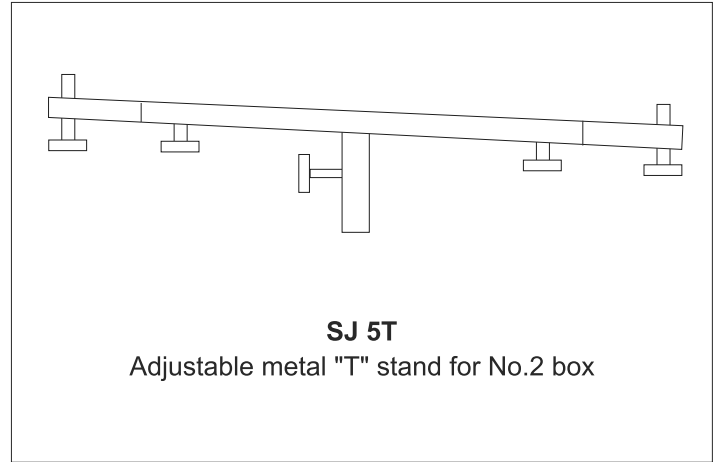
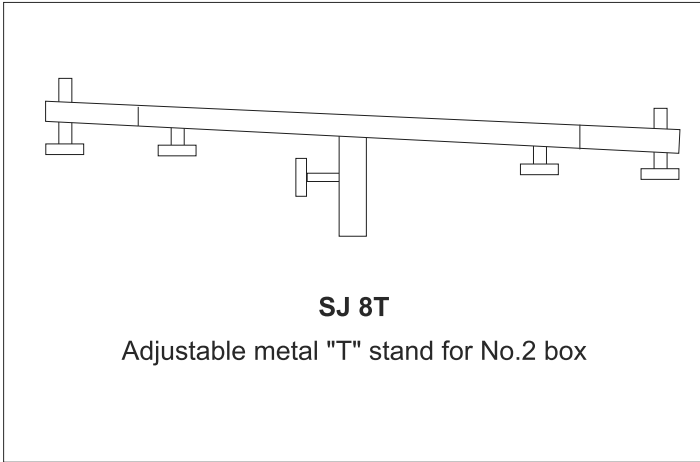

SAFETY INSTRUCTIONS

- "J" sound speakers must be installed using the flying accessories described in this manual and following the special assembly instructions by qualified staff only, strictly complying with the current regulations and safety standards in force in the country of installation.
- FBT flying accessories are manufactured for their exclusive use with "J" systems and have not been designed for being used with any other speaker or device.
- Any possible elements of the ceiling, floor or further supports where "J" systems are to be installed shall be able to safely bear the load.
- The flying accessories in use are to be coupled and secured safely to both the sound speaker and the ceiling (or the other support).
- When components are fitted to ceilings, floors or beams, always make sure that all couplers and fixing elements are properly sized and have an adequate load capacity.
- Besides the main suspension system, all flying speakers in theatres, indoor stadiums or in several other work and /or leisure facilities shall be provided with an additional independent safety system with the adequate load capacity. Only steel cables and chains with certified load capacity can be used as an additional safety device.

- Hang "J" speakers using only original accessories
- When choosing the place of installation, the suspension cable and the mounting supports make sure they are able to bear speaker and flying accessories' weight with the proper safety factor
- As for fixed installations, always schedule and carry out special inspections on a regular basis in order to check all the parts that have to guarantee system safety over time
- Do not hang the system by the handles: handles have been designed for speaker transport, and are not suitable for its suspension
- Never lean on/hang from the flying speaker

FBT Elettronica SpA will not be held liable for damage or injuries caused by supports or structures which are not sufficiently sturdy or by incorrect installation.

"J" speakers can be installed as follow:

- Suspension by wall bracket
- Installation on tripod stand or coupled with the subwoofer
- Simple stack installation with the subwoofer on the ground

Suspension by wall bracket

- 1) Carefully choose speakers place of installation and make sure that the structure can bear box weight
- 2) Remove speaker's feet
- 3) Secure the bracket to the wall by using screws in all its fixing holes
- 4) Place the speaker between bracket arms and secure it through two M10 threaded inserts
- 5) Point the speaker as desired and lock it through the M6 pin

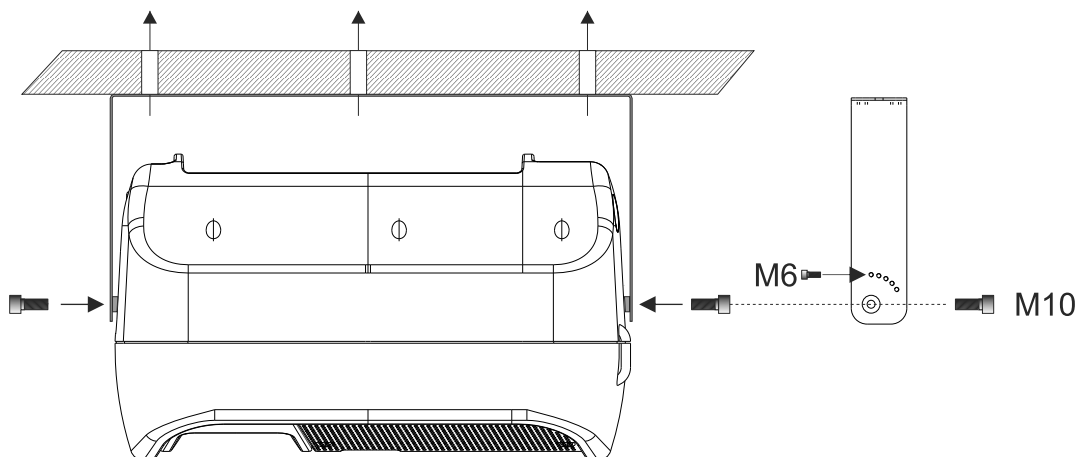

Installation on tripod stand

All "J" satellites are designed to be installed on floor stand. Such installation will allow medium-high frequency sources to be better aligned to listener's ear.

- Make sure that the stand can bear speaker's weight
- Place the stand on a flat and antislip surface
- Widen stand base as much as possible to increase its stability

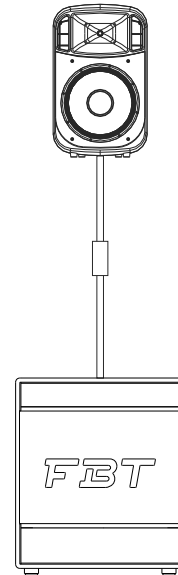
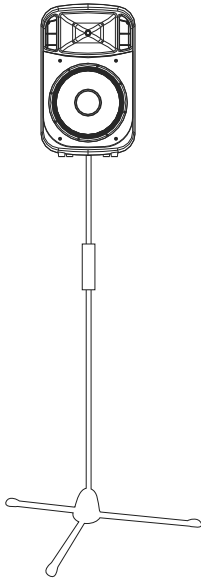

Stack installation

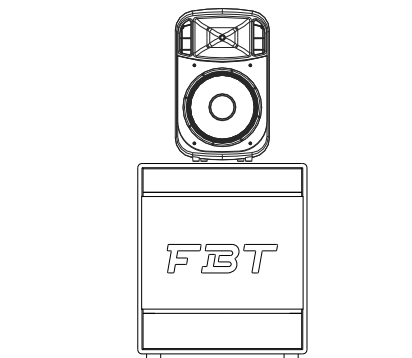

CONTROLS AND FUNCTIONS

PRT_ If this led lights up there is a system malfunction due to an internal amplifier failure.

ON_ Indicates that the system is on.

LINE / MIC_ Turn the switch to MIC if a microphone is connected; to LINE to connect high-level signal sources. Avoid sending a line signal (through mixer, etc.) while the MIC/LINE switch is positioned in MIC; failure to comply with this warning may cause damage or complete failure of speakers, woofers, high frequency drivers and internal power amplifiers. The MIC/LINE switch must be set to MIC only to connect a low impedance microphone.

HP FILTER_ This switch activates the "low cut" filter which lets only the frequencies above the cut-off frequency pass at the output (TO BE ACTIVATED IN THE CONFIGURATION WITH THE SUBWOOFER).

LEV_ Adjusts the signal general level.

IN / LINK_ Balanced input/output sockets; "IN" allows to connect a preamplified signal such as that coming, for instance, from mixer output; "LINK" allows to connect multiple speakers to the same signal.

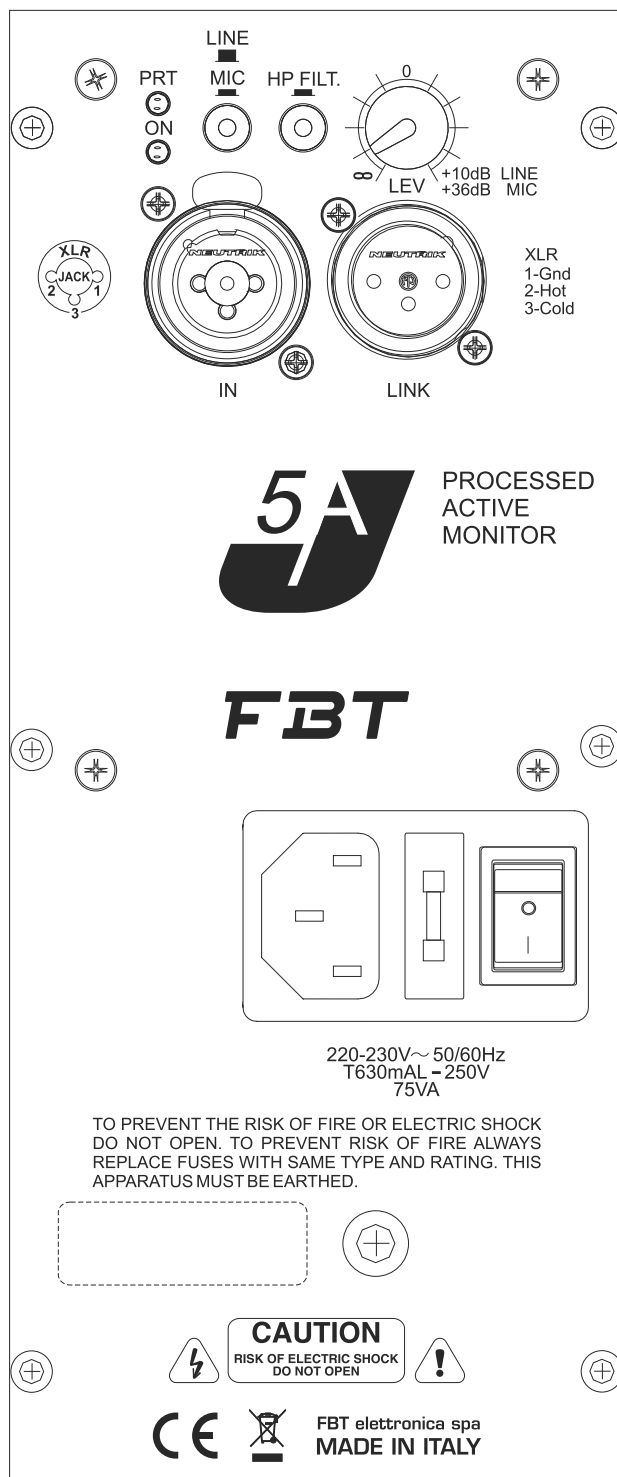

CONTROLS AND FUNCTIONS

PRT_ If this led lights up there is a system malfunction due to an internal amplifier failure.

ON_ Indicates that the system is on.

LINE / MIC_ Turn the switch to MIC if a microphone is connected; to LINE to connect high-level signal sources. Avoid sending a line signal (through mixer, etc.) while the MIC/LINE switch is positioned in MIC; failure to

comply with this warning may cause damage or complete failure of speakers, woofers, high frequency drivers and internal power amplifiers. The MIC/LINE switch must be set to MIC only to connect a low impedance microphone.

ORIGINAL / BOOST_ Equalisation presets for «general purpose» or bass boosting applications. ORIGINAL: corresponds to the typical «FBT» sound; it is the default general purpose preset and is thus fit for the majority of applications. BOOST: boosts band edges for full and surround timbre response

HP FILTER_ This switch activates the "low cut" filter which lets only the frequencies above the cut-off frequency pass at the output (TO BE ACTIVATED IN THE CONFIGURATION WITH THE SUBWOOFER).

LEV_ Adjusts the signal general level.

IN / LINK_ Balanced input/output sockets; "IN" allows to connect a preamplified signal such as that coming, for instance, from mixer output; "LINK" allows to connect multiple speakers to the same signal.

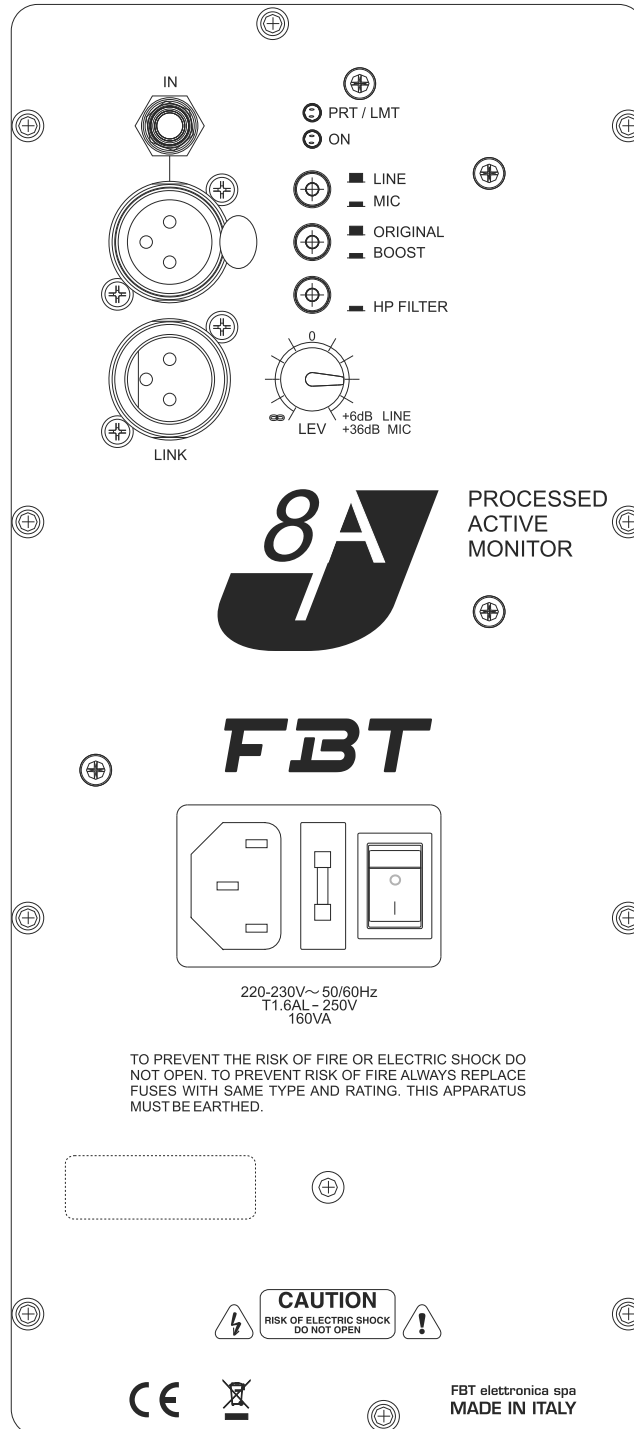

220-230V~50/60Hz
T1.6AL - 250V
160VA

TO PREVENT THE RISK OF FIRE OR ELECTRIC SHOCK DO NOT OPEN. TO PREVENT RISK OF FIRE ALWAYS REPLACE FUSES WITH SAME TYPE AND RATING. THIS APPARATUS MUST BE EARTHED.

CAUTION

RISK OF ELECTRIC SHOCK
DO NOT OPEN

CE



FBT elettronica spa
MADE IN ITALY



PRT / LMT_ If this led lights up there is a system malfunction due to an internal amplifier failure or to the intervention of current limiting circuits against thermal overload.

ON_ Indicates that the system is on.

LINE / MIC_ Turn the switch to MIC if a microphone is connected; to LINE to connect high-level signal sources. Avoid sending a line signal (through mixer, etc.) while the MIC/LINE switch is positioned in MIC; failure to comply with this warning may cause damage or complete failure of speakers, woofers, high frequency drivers and internal power amplifiers. The MIC/LINE switch must be set to MIC only to connect a low impedance

microphone.

PRESET_

ORIGINAL: Corresponding FBT benchmark sound for use in general applications.

FLOOR/VOCAL: The "J" immediately becomes an ideal stage monitor. Also suited for high clarity and intelligibility vocal reproduction.

BOOST/LOUNGE: Providing loudness contour with increased bass response for a relaxing and very enjoyable listening, especially at low and medium volume.

CLUB/DJ: Providing all the punch and full-bodied response required by DJ users, suitable for high volume "disco" and "party" applications.

HP FILTER_ This switch activates the "low cut" filter which lets only the frequencies above the cut-off frequency pass at the output (**T O B E A C T I V A T E D I N T H E C O N F I G U R A T I O N W I T H T H E S U B W O O F E R**).

LEV_ Adjusts the signal general level.

IN / LINK_ Balanced input/output sockets; "IN" allows to connect a preamplified signal such as that coming, for instance, from mixer output; "LINK" allows to connect multiple speakers to the same signal.

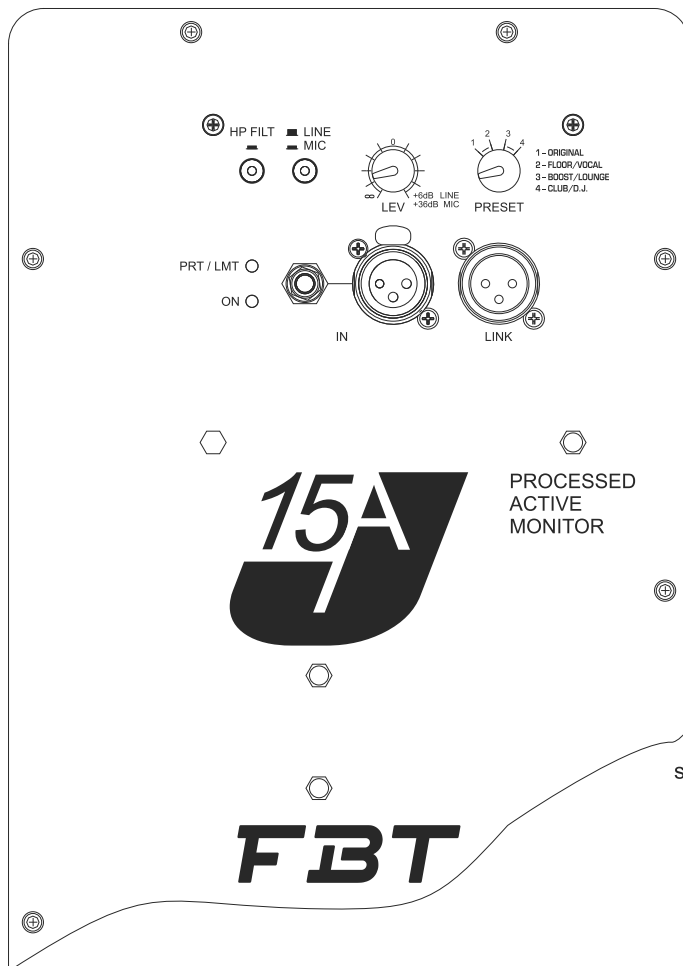

CONTROLS AND FUNCTIONS

PRT / LMT_ If this led lights up there is a system malfunction due to an internal amplifier failure or to the intervention of current limiting circuits against thermal overload.

ON_ Indicates that the system is on.

HP FILTER_ This switch activates the "low cut" filter which lets only the frequencies above the cut-off frequency pass at the output (TO BE ACTIVATED IN THE CONFIGURATION WITH THE SUBWOOFER).

PRESET_

ORIGINAL: Default preset, optimised for Djs use, featuring a timbre characterised by bass, not aggressive and perfect for playing disco music at the maximum power available.

BASS BOOST: Bass boosting preset, for an involving sound; dynamic capacity is slightly reduced, so this preset is suitable for medium volume.

SMOOTH: Preset with extremely linear response to be used for voice, acoustic music applications or when extremely high fidelity is required for the response.

LIVE: Optimised for live music: band, piano bar, etc.

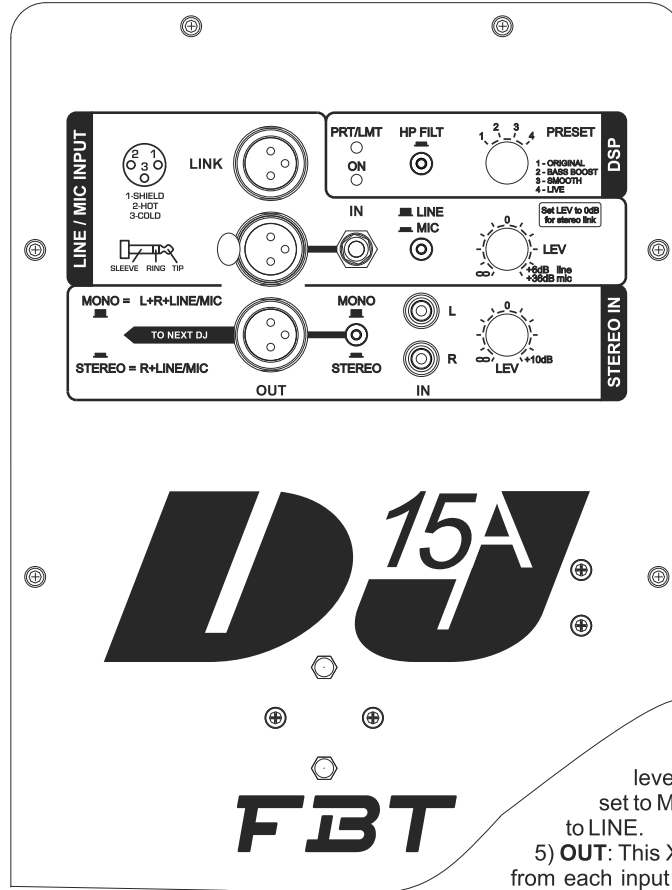

1) **IN**: XLR and jack input sockets (LINE/MIC channel) for connecting to a mixing console or a microphone, and RCA (STEREO channel) jack input sockets for connecting to a CD player or other portable players.

2) **LINK**: XLR output socket for parallel connection to IN sockets. It allows input signals to pass without any alterations.

3) **LEV**: For signal level adjustment at each input. If a device with nominal output level of +4dBu is connected (such as, for instance, a mixing console), set the MIC/LINE switch to LINE and adjust the level control LEV.

4) **MIC/LINE**: Set the switch to MIC or LINE for the IN sockets of the LINE/MIC INPUT channel, according to the input signal level; for low level signals, such as microphones, set to MIC; for high level signals, such as a mixer, set to LINE.

5) **OUT**: This XLR output socket sends the signals (coming from each input socket) to another DJ 15A connected. The signals on this input are line level signals. So, set the MIC/LINE switch of the connected speaker to LINE.

6) **MONO/STEREO**: It allows selecting stereo or mono signal playing. If a single DJ 15A speaker is used, set this switch to MONO; by setting it to STEREO, the audio signal input on the «R» channel of the RCA (IN) socket will be sent to the XLR output socket.

LINK MODE	STEREO		MONO	
	IN (Line/Mic Channel)	IN (Stereo Channel)	IN (Line/Mic Channel)	IN (Stereo Channel)
Input of the original DJ15A		L R		L R
Acoustic Output of the original DJ15A	✓	✓ -		✓
Acoustic Output of the linked DJ15A	✓	- ✓		✓

CONTROLS AND FUNCTIONS

On model «J5" jack socket (A) and terminals (B) are connected in parallel. Either the jack or the terminals must be used to connect the speaker to the output of a power amplifier or a mixer with built-in amplifier. Use the remaining connection to hook up a second system.

The «J5T» model is equipped with a line transformer. Therefore, the power amplifier must feature constant 100V or 70V voltage outputs. The loudspeakers, connected in parallel to the amplifier output, will make it easy to amplify the system deriving from any of the speakers installed previously, if necessary; in the same manner loudspeakers which are no longer necessary can be eliminated. In the connections, the «phase» both of the individual speaker to its transformer and the in-parallel connection of speakers must be respected. The input voltage of the speaker must correspond to the output voltage of the amplifier; the sum total of the rated power outputs of all the speakers connected to the line must not exceed that of the amplifier.

Before any connection adjust the input voltage and output power by acting on the two selectors (C).

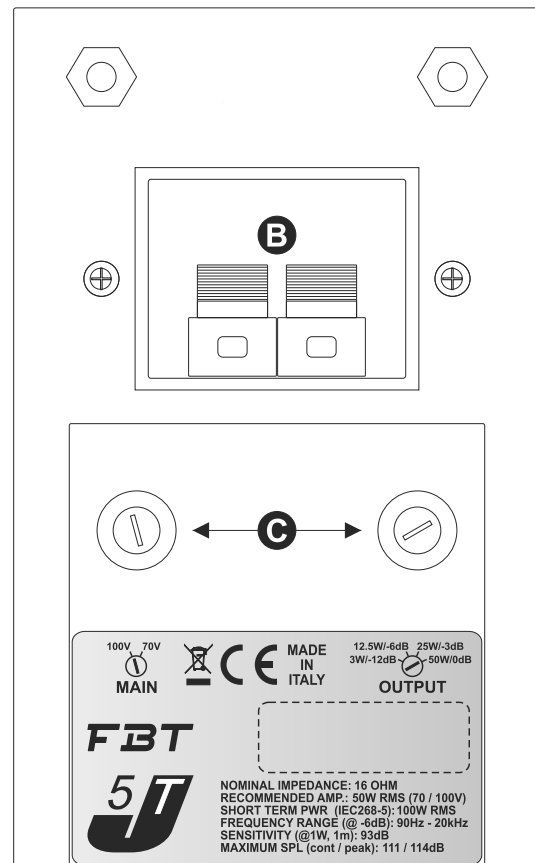
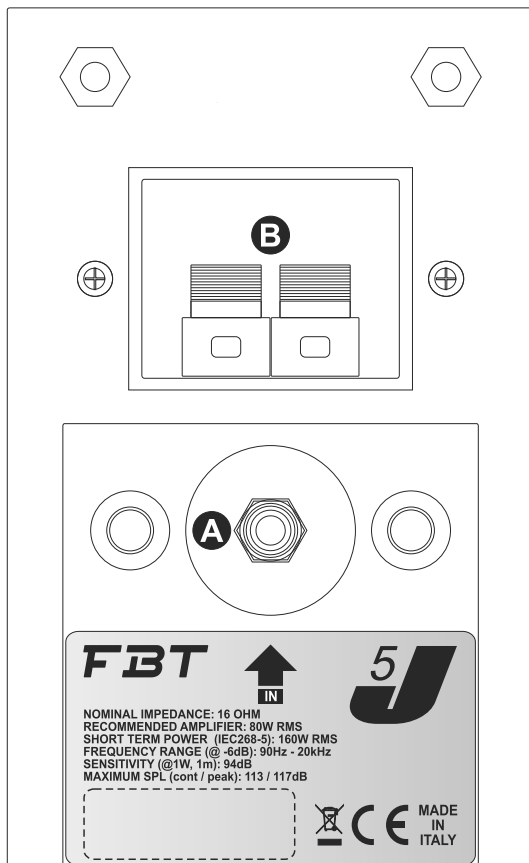

CONTROLS AND FUNCTIONS

Speaker connectors are connected in parallel mode. One connector can be used to connect the box to the output of a power amplifier, the other to connect to a second box.

Loudspeaker cables shall have the adequate diameter, depending on the overall length of the connection. The resistance introduced by an inadequate wiring towards the loudspeakers would reduce both the power output and the damping factor of the loudspeaker.

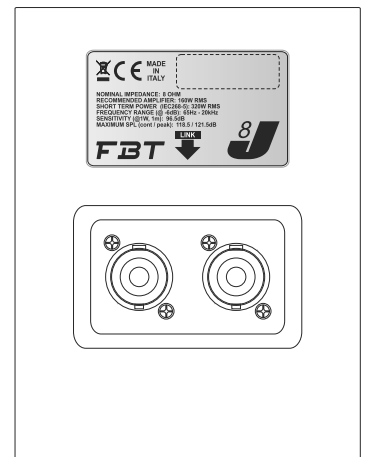
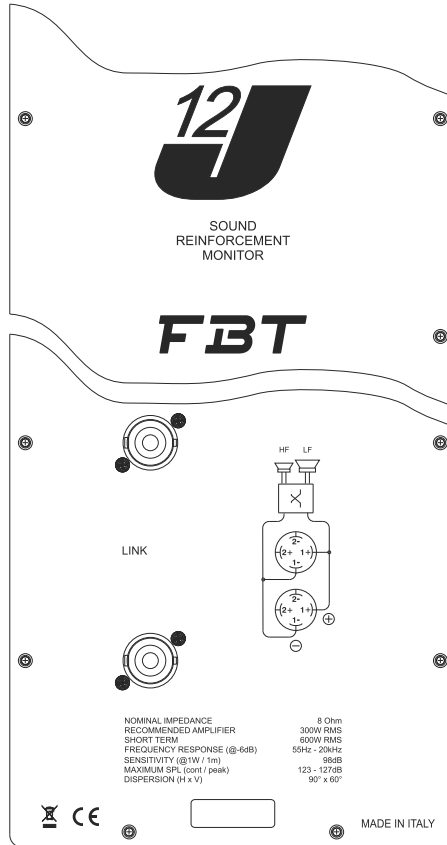
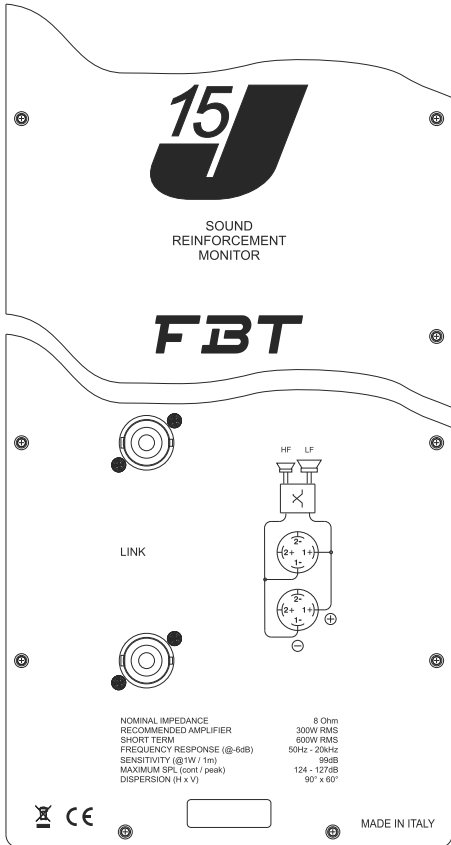

CONNECTION EXAMPLES

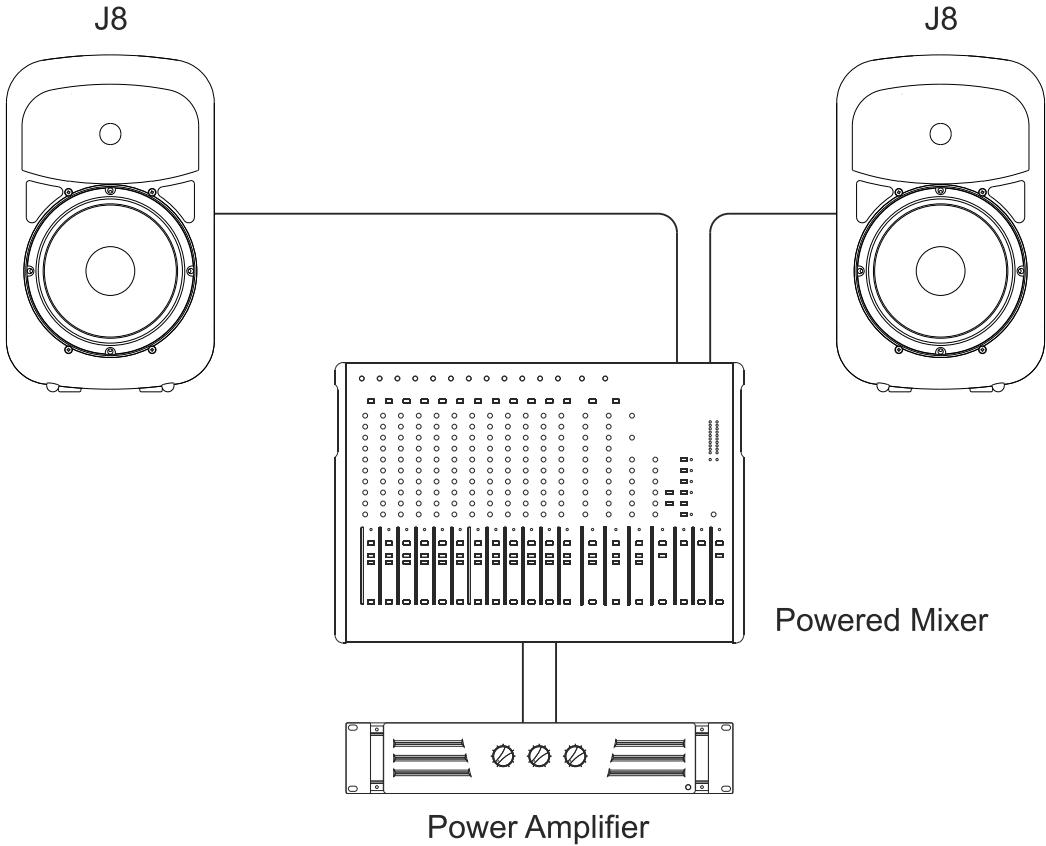
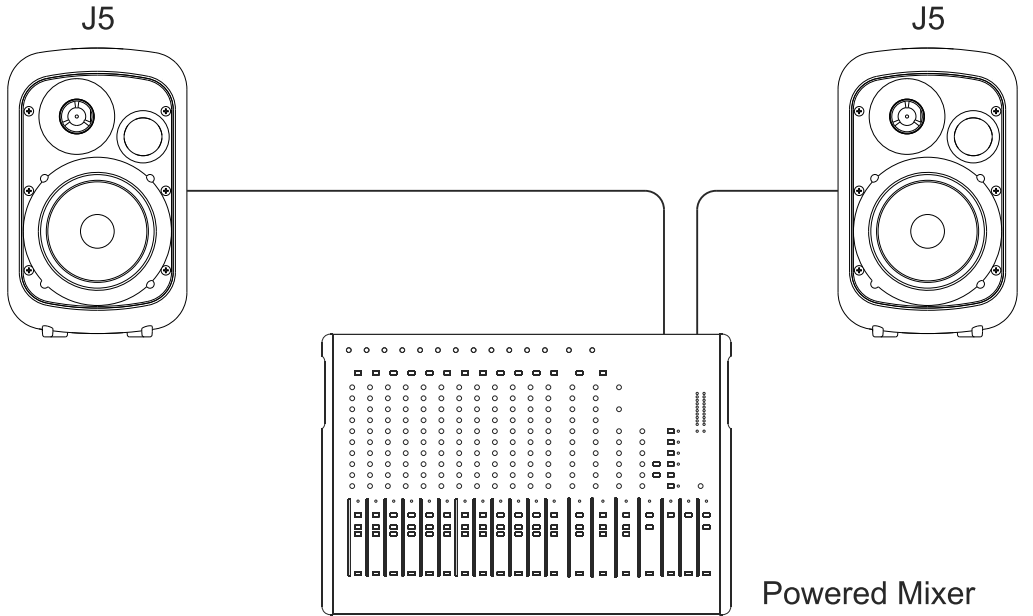

CONNECTION EXAMPLES

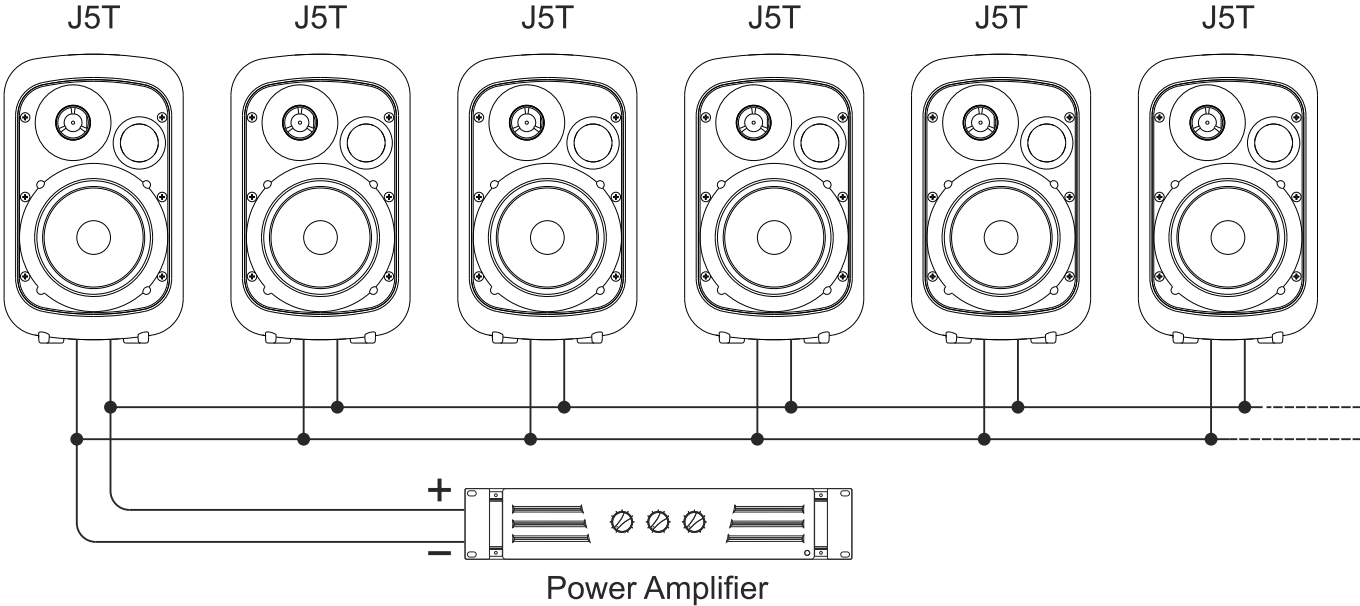
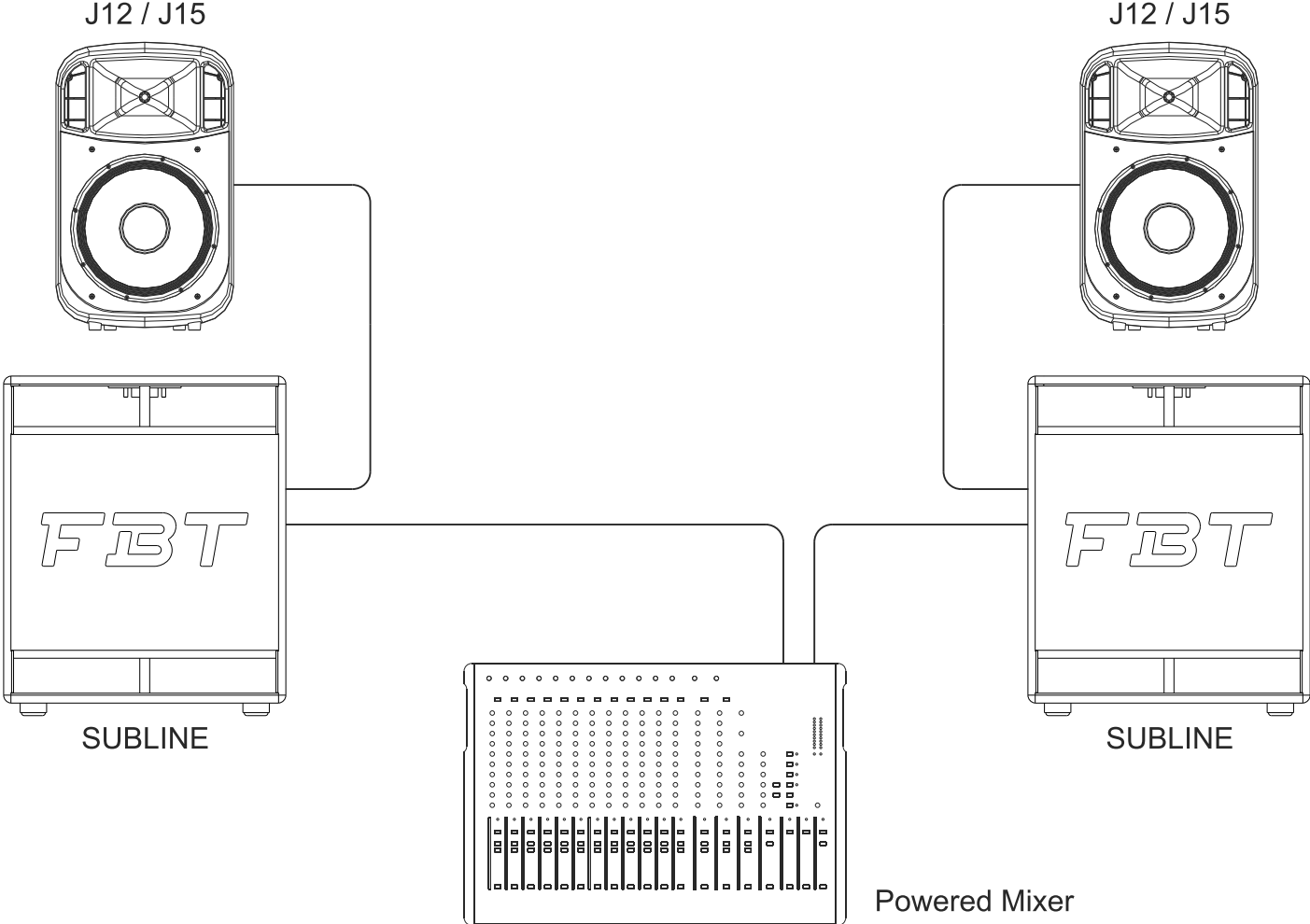

CONNECTION EXAMPLES

J12A / J15A / J5A / J8A

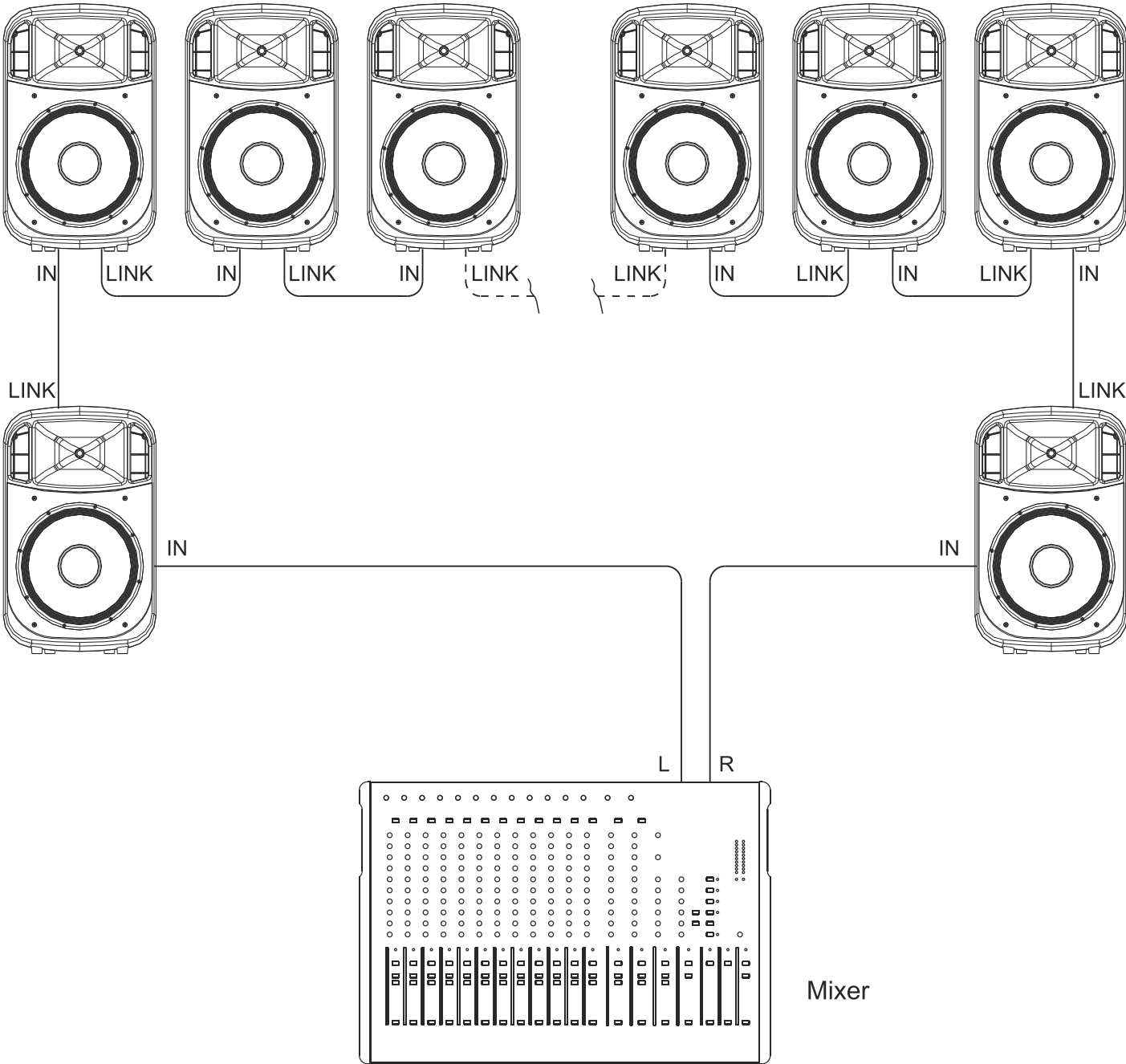

CONNECTION EXAMPLES

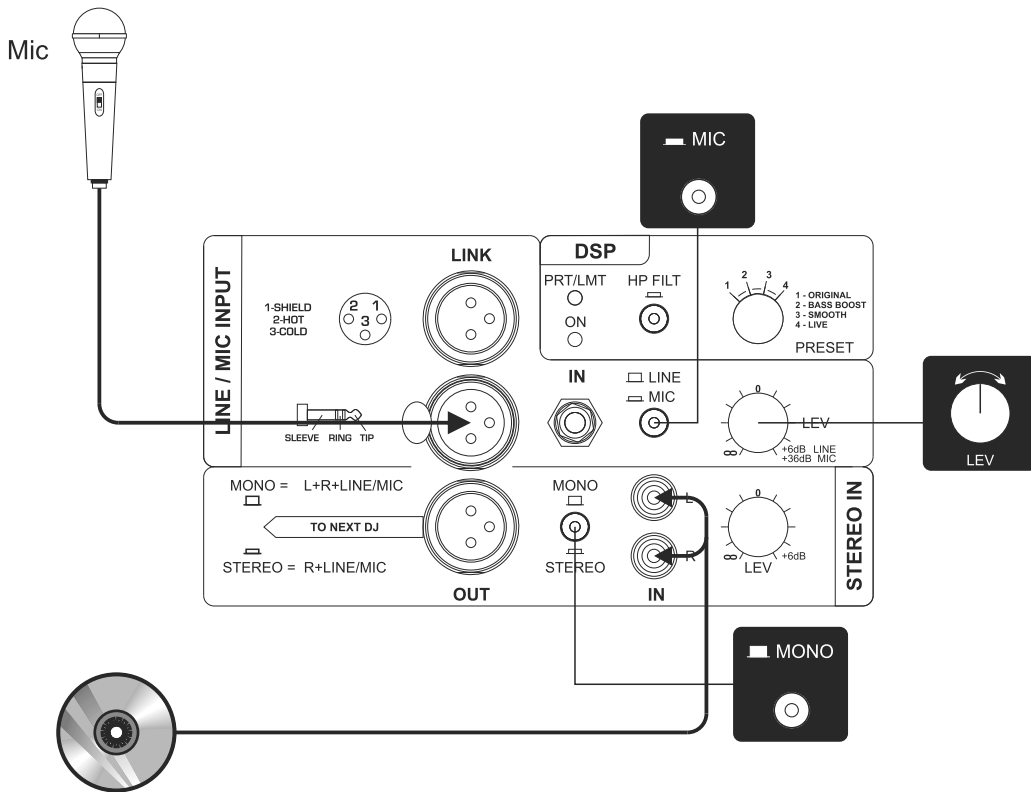
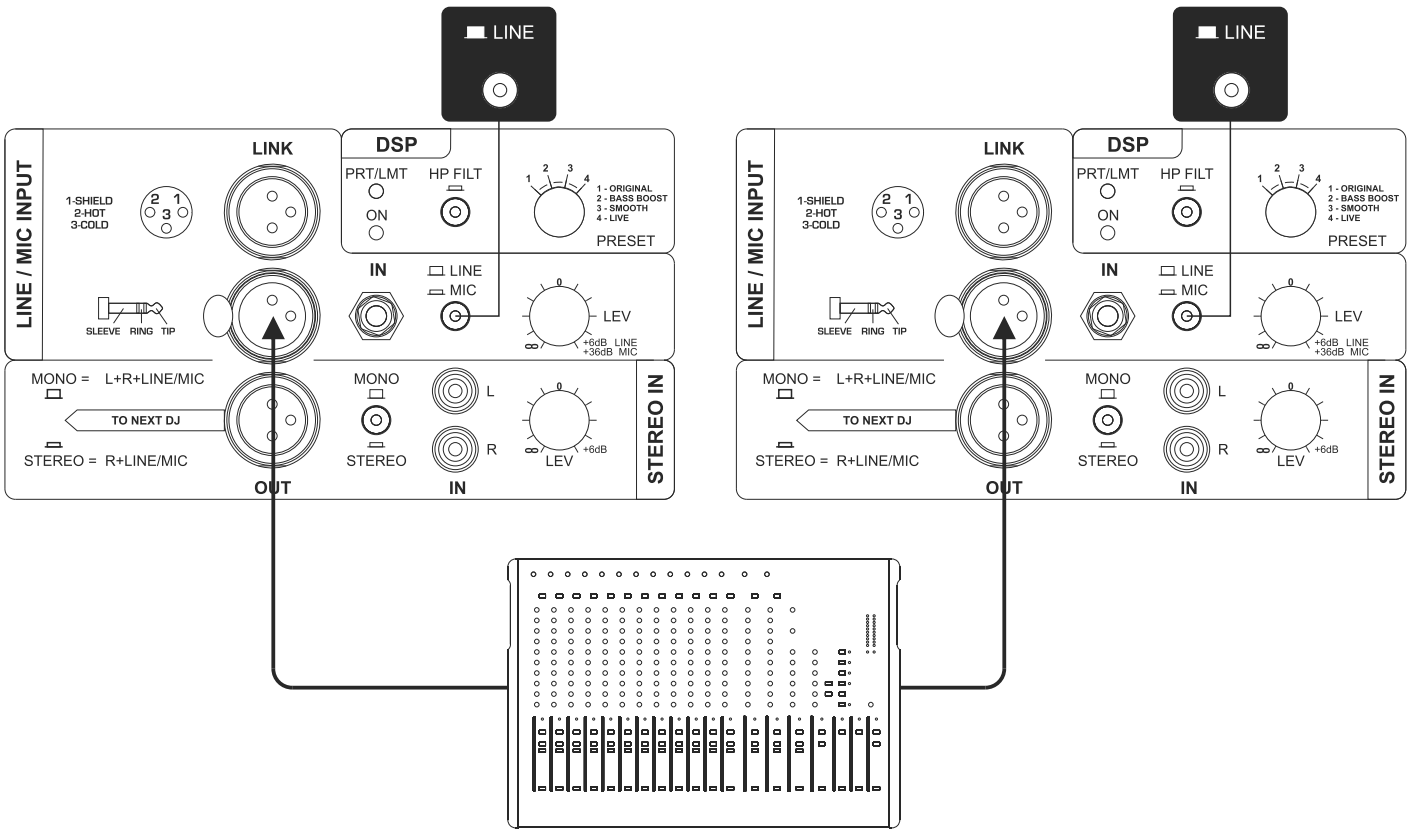

Portable audio player

CONNECTION EXAMPLES

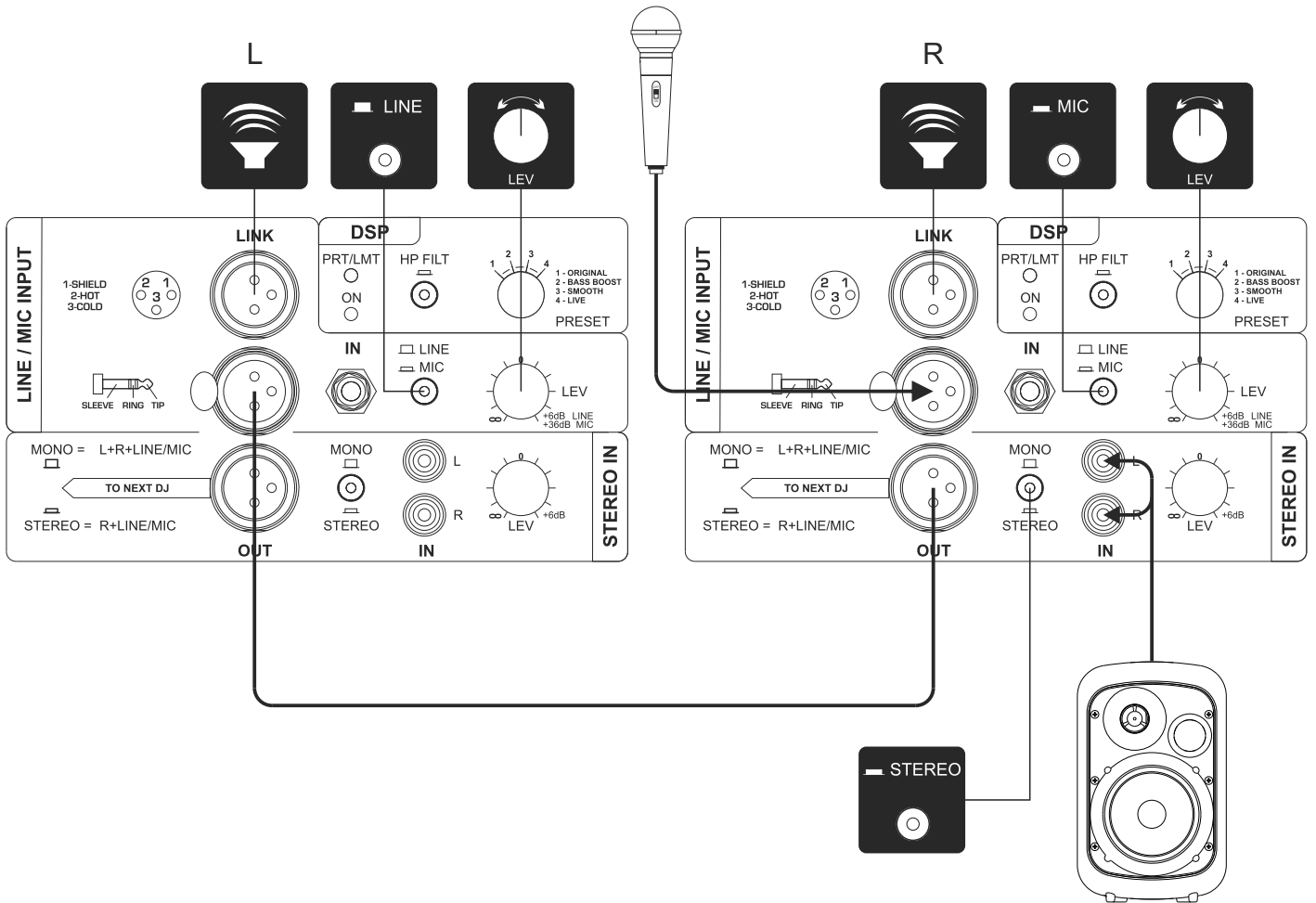

TECHNICAL SPECIFICATIONS

		J15A	J12A	J8A	J5A	DJ15A
Configuration	way	2	2	2	2	2
Built-in amplifier cont. RMS LF/HF	W	300 / 70	300 / 70	150 / 40	60 / 30	300 / 70
Built-in amplifier max. RMS LF/HF	W	350 / 100	350 / 100	200 / 50	80 / 40	350 / 100
Built-in amplifier max. peak LF/HF	W	700 / 200	700 / 200	400 / 100	160 / 80	700 / 200
Frequency response	@-6dB	48Hz - 20kHz	50Hz - 20kHz	60Hz - 20kHz	80Hz - 20kHz	48Hz - 20kHz
Low frequency woofer	inch	15 - 2 coil	12 - 2 coil	8 - 1.7 coil	5 - 1 coil	15 - 2 coil
High frequency driver	inch	1 - 1 coil	1 - 1 coil	1 - 1 coil	1 dome - 0.75 coil	1 - 1 coil
Maximum SPL cont / peak	dB	125 / 129	124 / 128	120 / 124	113 / 117	125 / 129
Dispersion	H x V	90° x 60°	90° x 60°	90° x 60°	90° x 90°	90° x 60°
Input impedance	kOhm	22	22	22	22	22
Crossover frequency	kHz	1.8	2	2.5	3.5	1.8
AC power requirements	VA	400	400	160	75	400
Input connectors		XLR-Jack with loop	XLR-Jack with loop	XLR-Jack with loop	XLR-Combo with loop	XLR-Jack with loop stereo RCA - XLR out
Power cord	ft	16.40	16.40	16.40	16.40	16.40
Net dimensions (WxHxD)	inch	16.14x26.10x15.23	16.14x26.10x15.23	10.03x16.33x9.64	6.69x10.82x7.08	16.14x26.10x15.23
Net weight	lb	30.86	30.2	18.7	7.49	30.86
Transport dimensions (WxHxD)	inch	19.48x29.13x18.70	19.48x29.13x18.70	12.99x18.89x12.59	9.44x13.58x9.25	19.48x29.13x18.70
Transport weight	lb	37.69	37.03	21.38	9.25	37.69
		J15	J12	J8	J5	J5T
Configuration	way	2	2	2	2	2
Recommended amplifier	W RMS	300	300	160	80	50 (70V / 100V)
Long term power	W	150	150	80	40	25
Short term power (IEC 268-5)	W	600	600	320	160	100
Nominal impedance	Ohm	8	8	8	16	16
Frequency response	@-6dB	50Hz - 20kHz	55Hz - 20kHz	65Hz - 20kHz	90Hz - 20kHz	90Hz - 20kHz
Low frequency woofer	inch	15 - 2 coil	12 - 2 coil	8 - 1.7 coil	5 - 1 coil	5 - 1 coil
High frequency driver	inch	1 - 1 coil	1 - 1 coil	1 - 1 coil	1 dome - 0.75 coil	1 dome - 0.75 coil
Sensitivity (@1W, m)	dB	99	98	96.5	94	93
Maximum SPL cont / peak	dB	124 / 127	123 / 127	118.5 / 121.5	113 / 117	111 / 114
Dispersion	H x V	90° x 60°	90° x 60°	90° x 60°	90° x 90°	90° x 90°
Crossover frequency	kHz	1.8	2	2.5	3.5	3.5
Recommended HP filter		40Hz - 24dB oct	45Hz - 24dB oct	55Hz - 24dB oct	80Hz - 24dB oct	80Hz - 24dB oct
Input connectors		2xSpeakon NL4MD-V in & thru	2xSpeakon NL4MD-V in & thru	2xSpeakon NL4MD-V in & thru	1xJack + terminal strip	terminal strip
Net dimensions (WxHxD)	inch	16.14x26.10x15.23	16.14x26.10x15.23	10.03x16.33x9.64	6.69x10.82x7.08	6.69x10.82x7.08
Net weight	lb	33.06	33.06	18.7	7.49	7.49
Transport dimensions (WxHxD)	inch	19.48x29.13x18.70	19.48x29.13x18.70	12.99x18.89x12.59	9.44x13.58x9.25	9.44x13.58x9.25
Transport weight	lb	37.91	37.91	17.85	9.25	9.25

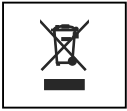

Important information for correct disposal of the product in accordance with EC Directive 2002/96/EC.

This product must not be disposed of as urban waste at the end of its working life. It must be taken to a special waste collection centre licensed by the local authorities or to a dealer providing this service. Separate disposal of electric and/or electronic equipment (WEEE) will avoid possible negative consequences for the environment and for health resulting from inappropriate disposal, and will enable the constituent materials to be recovered, with significant savings in energy and resources. As a reminder of the need to dispose of this equipment separately, the product is marked with a crossed-out wheeled dustbin.

CODE 37696#190913

All informations included in this operating manual have been scrupulously controlled; however FBT is not responsible for eventual mistakes. FBT Elettronica SpA has the right to amend products and specifications without notice.